

APPROVED AS NOTED FOR PRODUCTION	DATE
APPROVED FOR PRODUCTION	/ /05
REVISE AND RESUBMIT	
AUTHORIZED SIGNATURE	

DUMBWAITER PLAN

CALL/SEND BUTTON - BLOCKOUT
2 1/4"W X 3 3/4"H X 3"D

HOISTWAY DOOR BY OTHERS W/CLOSING
DEVICE OR MAGNETIC LATCH.

LEAVE FRONT WALL OPEN AT BOTTOM
LANDING UNTIL EQUIPMENT IS INSTALLED

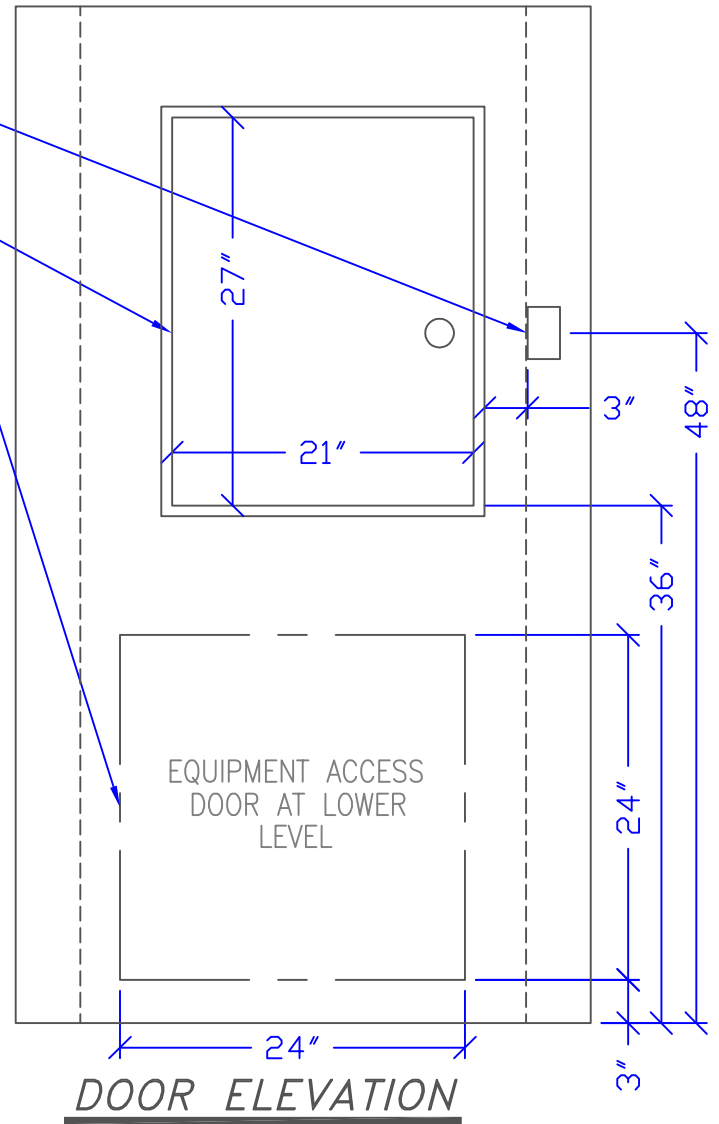

DOOR ELEVATION

MODEL	RD-2	# CAR OPENINGS	1
SPEED	18 FPM	DOOR LOCK	ELECTRIC
TRAVEL	-	CAB CONSTRUCTION	MELAMINE
# OF LANDINGS	2	HATCH WIDTH	-
SERVICE	RESIDENTIAL	HATCH DEPTH	-
CAPACITY	200#	MACHINE LOCATION	BELOW
OPERATION	CALL/SEND		

ELEVATOR CONCEPTS LTD.

JOB NAME:	SALES	
ADDRESS:	-	
CITY:	-	
ARCHITECT:	-	
CONTRACTOR:	-	
CUSTOMER:	-	
REVISIONS:	-	
DR. BY: TJM	DATE: 08/15/05	DWG: SALES