



DESIGN AND PLANNING GUIDE
TIGERLIFT ELEVATORS
APRIL 2013

Elevator Concepts Ltd. by Wurtec

18720 Krause Riverview, MI 48193 | 734.246.4700 | Fax: 734.246.2547
www.elevatorconcepts.com

TIGER LIFT ELEVATORS DESIGN AND PLANNING GUIDE

Elevator Concepts' TIGER LIFT series of elevators is designed to meet the need for small, high quality, and economical elevators in a variety of applications. This extensive and versatile product line can fit just about any site plan and budget. Several platforms are designed to accommodate modifications to allow for extensive customizing. This Design and Planning Guide has been prepared to help you choose the right TIGER LIFT for your application.

Why choose a TIGER LIFT? We know there are other elevator manufacturers that want your business. Here are several reasons why choosing the TIGER LIFT line of small elevators is the best choice you can make:

WE'RE SPECIALISTS

Elevator Concepts has been designing and manufacturing small elevators exclusively since 1985. We have the experience to manufacture cost competitive standard units as well as highly customized special units.

WE INSIST ON QUALITY

We design our own equipment in house - you will not see copycat engineering in a TIGER LIFT. Component parts utilized in our elevators come only from the finest suppliers in the industry. We are not the least expensive elevator manufacturer; we are the highest quality manufacturer. While price is important, you won't be thinking about the bargain you got when you're having trouble with the equipment.

WE GIVE YOU MORE CHOICES

There are more options available for TIGER LIFT elevators than any other small elevator product line. If you need an option or configuration that you don't see in this guide, we'll be happy to investigate the possibilities of supplying it. Customer suggestions play an important role in our ongoing process of improvement. Custom designs are our specialty.

WE DELIVER GREAT VALUE

We know that there are alternatives when looking for access solutions. You'll find that dollar for dollar, a TIGER LIFT will provide more use than other types of access devices. Most people prefer the security and comfort of a fully enclosed elevator car over an open platform lift. The investment made in a fully enclosed elevator will result in more usage than a similar investment in a platform lift.

WE DELIVER GREAT SERVICE

We build the best elevator possible at the best possible price. If you have any problem with a TIGER LIFT, it is our problem too. We support our products - our commitment is just beginning when the elevator leaves our plant. Our goal is to deliver a complete elevator that installs easily and functions properly. We meet that goal the vast majority of the time, but if we fail in any respect, we will do whatever it takes to satisfy you. No questions asked.

TIGER LIFT PRODUCT LINE

RESIDENTIAL SERIES

The residential series offers the same dependability and innovative designs of our commercial elevators, but are designed for the loads and sizes required in typical residential applications to offer cost savings. Our residential series uses commercial grade 8lb T-rail, and should not be confused with light duty units, which use uni-channel or other less robust guide rails. A full range of performance and aesthetic options are available, as is custom design – the hallmark of Elevator Concepts LTD by Wurtec.

TYPE XD

This is our drum machine model. It features a 950# capacity at 35 feet per minute, powered by an efficient and quiet helical bevel machine controlled by a variable frequency drive for an extremely smooth ride, and instantaneous broken rope safeties. We offer three different machine configurations, allowing us to accommodate almost any building condition.

TYPE X5R

This is our roped hydraulic model. It features a 950# capacity at 40 feet per minute, powered by a submersible screw pump unit with a two speed valve for smooth & quiet starts and stops, leveling/anticreep operation. Instantaneous broken rope safeties and an overspeed valve prevent the elevator from falling if there is a problem with the hoist ropes or hydraulic system. No well hole is required for the hydraulic cylinder. The pump unit can be located almost anywhere to accommodate any building condition.

TYPE X3R

This is our direct hydraulic model. It has the same features as the X5R roped hydraulic, except that a partial well hole is required for the hydraulic cylinder, and the broken rope safeties are omitted.

If your requirements exceed the capabilities of our residential series, one of our commercial elevators can be adapted to your requirements.

COMMERCIAL SERIES

X5C- This is the heavy duty version of our roped hydraulic model. It is similar to the X5R but with a 1400# capacity. It can accommodate larger car sizes, including those designed for commercial elevator side sliding doors.

ETL listed programmable controller
ETL listed door interlocks

TIGERLIFT FEATURES AND OPTIONS

The TIGER LIFT line of small elevators comes with a number of features in their standard configuration; this standard configuration is designed to be a complete package with all equipment required for an installation designed to meet most code requirements. The TIGER LIFT line has a wide range of options available to satisfy specific owner needs and code requirements. The options described below are operational in nature, and deal with function instead of appearance. There are numerous options for cab and fixture appearance; it would be impossible to list these. If you have an option in mind that is not listed, please consult the factory for availability - most likely we have done it before.

TANK HEATER: a 75 watt thermostatically controlled submersion heater to keep hydraulic fluid from getting too cold. Used where machine room temperatures will drop below 50 degrees.

AUTO LOWERING: a special valve, control circuit, and battery power supply which will allow the elevator to descend to the lowest level in the event of a power failure. Can be designed for automatic or push-button operation.

POSITION INDICATOR:

RETIRING CAM: device used to operate true door interlocks. Used where required by code.

DOOR MONITOR: a buzzer which sounds when a call button is pushed, but the car cannot run because a door or gate is open.

ARRIVAL GONG: a gong which sounds as the car stops at a landing.

ARRIVAL LIGHT: a light which activates as the car stops at a landing.

KEY SWITCHES: used in place of or in conjunction with call buttons. Used for security or where required by code. Many variations possible - contact the factory for specific applications.

IN USE LITE: used in conjunction with key switch to show that call has been registered.

CAR TOP STATION: used to operate unit from on top of car. Used where required by code or when desirable, usually on higher rises.

FIRE SERVICE: recalls car to main floor. Used where required by code.

EMERGENCY LIGHT: low level cab lighting which comes on automatically during power failure.

SCISSOR GATE: "Bostwick" style collapsing gate.

WRAPAROUND GATE: Solid panel gate which does not collapse, but rolls around the side of the car.

GATE OPERATOR: Power operation for either the standard woodfold gate or the sideslide gate option.

ESCAPE HATCH: Removable roof section for emergency access to cab. Used where required by code.

TRAVEL RESTRICTOR: Required by Section 25 LULA code when pit is less than 36" or overhead is less than 136"

HORIZONTAL SIDESLIDE ENTRANCES: Traditional elevator style entrances and frames.

APPLICATION GUIDELINES

With so many models to choose from, it may seem difficult at first to make the best choice for a particular application. As with any guideline, this brief explanation is not intended to cover every single design application question, but rather be a guide. In some cases a standard model will not fit the application. Whenever you have any application questions, give us a call!

The first question to answer when selecting an elevator is “What exactly do we expect the elevator to accomplish for us?” This can be broken down into several more specific questions, which are appropriate for all types of elevators:

- How much weight must it lift?
- How fast should it lift it?
- How many landings will be served?
- How large does the cab need to be? (how big are the things going on the elevator?)
- Are automatic doors or gates required?

There will probably be several different models to fit the bill based only on the answers to these questions. Next, we have to answer questions about the building structure that will support the elevator:

- What size is the hoistway?
- What is the wall construction?
- How deep is the pit?
- How high is the overhead?
- What kind of power is available?
- Is a machine room available?
- Is an overhead machine space available?
- How many car openings are required to suit the floor plan?
- Is underground drilling a problem?

These answers will usually narrow the available choices down. Finally, we establish which options are desired and available. This leaves us with the final choices available. At this point, the selection is generally determined by price. To generalize, we offer these broad guidelines:

Drum machines Our overhead drum machine eliminates the problems typically associated with winding drum residential elevators: noise, ride quality, structural machine room floor; and safety concerns if the motor contactor welds shut. Elevator Concepts LTD drum machines start with a highly efficient helical bevel gearbox, which is compact, powerful and quiet. With as little as 8’ at the top landing, we can mount the machine on top of the guide rails – eliminating a separate machine space and the structural requirements for attaching it. Our new programmable controller controls the machine, with variable frequency drive for extremely smooth stops and starts and many safety features. An optional battery backup emergency lowering system is available.

Hydraulic machines have gained wide acceptance in all applications, from residential to heavy duty freight. In the TIGER LIFT line, we offer both direct and roped hydraulic. Direct hydraulics are less expensive, but most require a well hole for the hydraulic cylinder. For applications with travel 12' or less, the well hole is generally not a problem, and the direct hydraulic is the most cost effective. For applications exceeding 12', or where site conditions preclude a well hole, the roped hydraulic is usually the most cost effective, as the added expense of the roped mechanism is usually less expensive than providing the well hole. Hydraulic elevators are fail-safe with regard to electrical system failure. Ride quality is excellent thanks to modern control valves. Submersible pumps make for very quiet operation, equivalent to a pool filter pump. Hydraulic machines require 220 power, a separate machine space, and at least one load bearing hoistway wall. While a hydraulic requires a lot of electrical power to go up, it requires none at all to go down. This inherent characteristic makes it very easy to move a hydraulic elevator during a power failure.

While each type of drive requires different types of maintenance and safety tests, overall cost of maintenance of all types tends to be fairly equal over the long run. Elevator Concepts LTD recommends maintenance inspections on a quarterly basis as a minimum, regardless of the type of elevator. Local code may require a different frequency. For cars with a safety, we recommend a no load test every year, and a full load test every 5 years. For cars with buried hydraulic equipment, we recommend that the cylinder be tested every year. Hydraulic pressure relief valves should also be tested every year.

A winding drum or roped hydraulic machine in terms of both performance and price best serves the majority of residential installations. For LULA elevators, roped hydraulics are the most appropriate. For residential or LULA applications with "traditional" elevator type sliding door applications, we recommend roped hydraulic models.

Typical layout drawings for LULA and residential applications are available in this guide. It is not possible to depict every possible configuration in a planning guide of this type. Hoistway sizes, car sizes and landing configurations are available in a wide range for each type of elevator. Custom sizes and configurations to overcome existing site limitations are also possible. The chart following the drawings summarizes the characteristics of each model of the TIGER LIFT line.

If you can build your hoistway to suit, you can take advantage of the savings available with our pre-engineered sizes. If your job conditions will not accommodate a standard size unit, we can build a custom unit to suit.

Codes and designs are subject to change without notice. Before committing to design or construction, consult with your elevator contractor, or contact our engineering department.

TIGER LIFT ELEVATORS

DESIGN & PERFORMANCE DATA

	X3C	X5C	XD	X3R	X5R
MACHINE TYPE	Hydro	Roped	Drum	Hydro	Roped
MAXIMUM CAPACITY	1400	1400	950	950	950
STATIC CAPACITY	7000	7000	3800	3800	3800
MAXIMUM PLATFORM	42X60	42X60	40X54	40X54	40X54
MAXIMUM STOPS	6	6	6	6	6
MAXIMUM TRAVEL	15	50	40	15	50
SPEED	30	30	35	40	40
POWER REQUIREMENT	220	220	220	220	220
MINIMUM PIT	12"	12"	6"	6"	6"
MINIMUM OVERHEAD	9'	9'	8'	8'	8'
GROSS PIT LOAD	3000#	3000#	2400#	2200#	2200#
GROSS BRACKET LOAD	300#	300#	300#	300#	300#
RAIL SIZE	8#	8#	8#	8#	8#
MAXIMUM CAR GATES	2	2	3	3	3
BUFFERS	STD	STD	STD	STD	STD
STEEL GATES	OPT	OPT	NA	OPT	OPT
VVVF DRIVE	NA	NA	STD	NA	NA
OPTIONAL HIGH SPEED	60	60	NA	60	60
AUTO DOORS/GATES	OPT	OPT	OPT	OPT	OPT
SIDESLIDE ENTRANCES	OPT	OPT	NA	NA	NA

You won't find a "typical" shop drawing for every model in this guide because we don't believe there is a "typical" elevator. Elevator Concepts LTD manufactures the widest array of pre-engineered and custom small elevators available, and can supply just about any imaginable combination of configuration, fixtures, finishes, and options. It would be impossible to put them all in this guide. Even if we could, it would be difficult for most people to determine the right plan to use.

We provide working drawings for architects and engineers upon request. By spending just a few minutes with you early in the design process, we can save you a lot of time and trouble by providing just the right information. Please contact us to request working drawings.

In the back of this guide, you will find sample hoistway plans for our most popular pre-engineered sizes. Using a pre-engineered system will save you time and money.

Before you use any information contained in this guide for design or construction, please consult us. Code and design changes can make this information obsolete at any time!

TIGER LIFT STANDARD SPECIFICATIONS GENERAL SPECIFICATIONS

CAR FRAME:

Frame shall be constructed of steel, rigidly reinforced and gusseted, bolted and welded to insure durability including steel crosshead, safety plank, platform beams, stringers, side stiles, buffer strikes, and mounting holes for guide rollers. Provide cable hitch and safety actuating mechanism where applicable. Provide reinforced adjustable platen assembly for hydraulic units. Platform shall be 1-1/4" thick plywood. The entire car frame assembly shall be capable of sustaining a minimum static load of 5, or greater as required by code.

GUIDE RAILS:

Steel T rails shall be machined to exact tolerances for smooth travel. Guides shall be stabilized by adequate adjustable steel brackets as required, and secured to hoistway with suitable fasteners. Guides shall have a nominal weight of 8 lbs/ft.

GUIDE ROLLERS:

Adjustable car roller guides shall be fitted to the frame, and shall the rail with a minimum of clearance. Roller wheel shall be nylon with a precision roller bearing, machined for close tolerance. Roller wheel shall be fitted to an eccentric axle pin which is field adjustable.

BUFFERS:

Compression springs of sufficient stroke and capacity shall cushion the car and counterweight in the event of overtravel.

CONTROLLER:

Controller shall be enclosed in a NEMA 12 cabinet. Controller shall be of the electro-magnetic type, designed to prevent damage to the motor from overload or excessive current. The controller shall automatically stop the motor and set the brake if any safety device becomes operative. A non interference relay shall be provided. Momentary pressure on a car or hall button shall send car to the desired floor if all safety circuits are made up.

CAB:

Cab walls to be 3/4" panels, finished as required by code and to meet design specifications. Car shall be fitted with a collapsing gate at each opening, conforming to applicable code. Canopy shall be 3/4" panel, laminate finish with 2 recessed incandescent light fixtures. Canopy shall be capable of sustaining 100 lbs/sq.ft.-(500 lbs total. Cab shall be furnished with at least one handrail; standard handrail to be 1-1/2" diameter, brushed stainless finish.

GATE:

Standard gate to be wood folding accordion type, with concealed spring hinges. Panels to have stabilized wood core faced with semi-rigid vinyl film, 6 mil minimum, pressure laminated. Natural wood veneer optional. Hanger assembly of dual nylon rollers shall be installed on alternate panels. Gate shall be suspended in track of no less than 20 gauge metal. Gate shall be fitted with lower guide pins and track.

FIXTURES:

Provide a car operating panel with illuminated buttons for each landing. Provide a light switch, alarm button, and emergency stop button. Provide an illuminated call button at each landing. Standard fixtures shall have stainless steel face plates, #4 finish; optional materials and finishes available.

HYDRAULIC ELEVATORS

MACHINE:

Pumping unit to be of unitized construction, including steel reservoir of adequate capacity with filler, strainer, sight gauge and magnetic drain plug, direct coupled gear type positive displacement pump, heavy duty motor externally flange mounted for ease of service, and unit valve and line shut off valve.

PUMP:

Standard pump shall be high tolerance 3 screw set of hard nitrided steel, balanced to eliminate all axial loading. Input shaft to be supported by motor grade roller bearing. Housing to be extruded from G-Al-Si-12 Cu-Mg-NI alloy, with integral steel strainer.

VALVE:

Hydraulic unit control valve shall be machined from solid aluminum billet, with the following field adjustable functions: check valve, relief valve, up start, up leveling speed, down start, down high speed, down leveling speed, down stop valve. Unit valve shall be equipped with self closing manual lowering valve, self cleaning strainer, pressure gauge, low pressure switch & shut off.

LEVELING DEVICE:

Provide automatic 2-way leveling device to maintain platform within 3/8" of landing. Leveling device to function when doors and gates are open or closed.

JACK UNIT:

The hydraulic jack unit shall comply with all provisions of ASME 17.1. The plunger will be machined true to a minimum smoothness of 12 micro-inches, and equipped with a suitable stop ring. The cylinder will be rated for 500 psi working pressure, and fitted with a safety bulkhead, seamless dished bottom cap, removable head, bearing, and packing, and provisions for air bleed and leakage collection.

ROPED UNITS:

The jack unit shall be equipped with a U-groove sheave to support hoisting cables. Sheave shall be mounted in a steel yoke and secured to plunger. Yoke shall be equipped with guide assembly to follow guide rails. Hoisting cables to be 3/8" x 8-19 traction steel, and shall terminate in wedge clamp type fasteners.

Type A instantaneous safety shall be located in a steel safety plank below the platform, capable of stopping and holding the car plus its rated load with a safety factor of 5 minimum. Safety shall be actuated by a slack cable mechanism or optional governor. Safety shall operate a switch to remove power from motor and valve. Safety shall release by raising the car.

WINDING DRUM ELEVATORS:

DRUM MACHINE:

Single reduction bronze ring and worm gear machine mounted on a structural steel base. Motor shall be face mounted, totally enclosed fan cooled. Motor shall have close coupled disc brake, 6 ft/lbs capacity, spring set, electric release. Machine shall be located as per job requirements. Drum shall be fabricated of DOM tubing, with accurately machined grooves to guide and support the hoist cables. The drum shall be fitted with tapered bushings in each hub to facilitate installation and removal. The drum shall have provisions to retain the free end of the hoist cables. The drum shaft shall be supported by an outboard pillow block roller bearing. Machine shall have an adjustable limit switch to remove power from motor and brake in the event of overtravel in either direction.

DRUM DEFLECTOR SHEAVES:

Deflector sheave shall be 6" steel, grooved to support cable without deformation. Sheaves to be fitted with precision needle bearings. Traveling deflector sheave shafts shall be rigidly supported and sized to allow minimal deflection.

OPTIONAL EQUIPMENT:**TANK HEATER:**

Heater shall be of the surface mount type, thermostatically controlled to automatically maintain oil temperature.

AUTO LOWERING:

Provide circuitry and auxiliary power supply to allow car to descend to lowest landing in the event of failure of the main power supply. All safety circuits shall be fully operational. Provide circuitry to allow for either automatic or passenger initiated descent of car.

Optional gate operator shall be a precision screw drive type, Porta Inc. Model KIS100 or equivalent.

RETIRING CAM:

Heavy duty parallel arm gravity-drop cam with sufficient weight to open interlock, with torque motor to raise cam to lock door.

SCISSOR GATE:

Collapsing gate shall be heavy duty Bostwick type, with a minimum of 11 stiles and a minimum of 2 sets of relating scissors. Gate shall conform to all applicable requirements of ANSI 17.1. Stiles shall be fabricated from rolled steel channel. Relating scissors shall be fabricated from 1/8" steel flat stock. Gate shall be suspended on every other stile by a 3 wheel truck assembly, with provisions for height adjustment. Wheels shall be ball bearing type with polyurethane tires. The bottom of each stile shall be fitted with a nylon guide. The entire gate assembly shall be coated with enamel.

GATE OPERATOR:

Optional gate operator shall be a precision screw drive type, Porta Inc. Model KIS100 or equivalent. Open and close speeds shall be fully adjustable. Magnetic clutch shall release gate in the event of an obstruction. Signal from main control shall actuate open or close operation. Optional reopening device shall stop gate from closing and return it to the open position.

SWING DOOR OPERATOR:

Mark IV by Door Motion Technologies. Electromechanical type utilizing parallel arm pull type actuation. Operator shall be mounted on hoistway door, or optionally on top of elevator car. Integral spring closer, adjustable opening speed and back check.

AUTOMATIC HORIZONTAL SLIDING DOORS

Car and hoistway doors shall open and close simultaneously at all levels. Door movement shall be fully adjustable, cushioned at both limits of travel. Operating mechanism shall be arranged to allow manual opening during loss of electricity when car is in the unlocking zone. Hoistway doors shall be self-locking and self-closing at all times.

Provide new door hangers and tracks. Hangers to be sheave type, no less than 2 per door, tired with a suitable sound reducing material and shall rotate on sealed ball bearings. Provide adjustable means to eliminate upthrust. Make modifications to existing doors and headers as required to accommodate hangers and tracks. Provide manufacturer's standard door closing device. Provide new sills, sill supports, struts, headers, frames, and door panels as required for a complete installation. Finish as specified above.

A solid state infrared door reversal device shall be installed on all car doors. The device shall be capable of detecting an opaque ball 1" in diameter anywhere in the within its path. Upon detection, the doors shall stop and reopen, after which the door shall again start to close. If the door is prevented from closing for approximately 30 seconds, the doors shall close at a reduced speed ("nudging"), regardless of the condition of the reversal device.

Provide 16 gauge hollow metal doors and 14 gauge frames finished as specified. Provide aluminum sill with guide groove for non-metallic bottom gibb. Provide mechanical spring type closing device for each entrance. Provide struts, headers, fascia, toe guards, hanger covers and hardware as required.

Elevator Concepts LTD continually improves its products, and reserves the right to modify these specifications at any time without prior notice. Please check with us or an authorized TIGER LIFT dealer before incorporating any specifications or dimensions in working construction documents. We are happy to review your documents at any time and will provide specifications tailored to your requirements at no charge.

TIGER LIFT & CODES

TIGER LIFT elevators, as manufactured by Elevator Concepts LTD and when properly specified, will meet the requirements ASME A17.1 Section 5.2 for Limited Use/Limited Access Elevators, and Section 5.3 for Residential Elevators.

The Section 5.2 LULA code allows for these basic parameters:

MAXIMUM LOAD	1400#
MAXIMUM SPEED	30 FPM
MAXIMUM PLATFORM	18 SQ FT
MAXIMUM TRAVEL	25 FT

The Americans with Disabilities Act is civil rights legislation designed to promote the removal of barriers. It is not a building code; technically, it does not require anything be done to any building. If buildings are not in compliance with the ADA, the Department of Justice can bring suit against the building owner, with penalties including making the building comply with ADA along with substantial fines. However, most of the model building codes such as BOCA now have design requirements patterned after the ADA., so new construction and renovation work will typically comply with ADA if it complies with the building code.

For new construction, or improvements to existing structures, the ADA does not required a full passenger elevator if a building has less than 3 stories, or if each story in the building is less than 3000 square feet, unless the building is a shopping mall, a medical office, or other type of building the government determines should have an elevator. If a full passenger elevator is planned for a building, whether required or not, it must meet the ADA requirements for elevators and serve every level, unless it is infeasible to do so. However, the ADA does not prohibit the installation of devices other than full passenger elevators in buildings where there is no requirement for vertical access. Since the TIGER LIFT is not a full passenger elevator, it is not subject to the requirements for a full passenger elevator when installed in buildings such as described above.

The ADA specifically allows platform or wheelchair lifts meeting local codes to be used to provide access to a performance area, to a specified wheelchair viewing area, incidental spaces for less than 5 people not open to the general public, and areas where it is infeasible to provide a ramp or an elevator.

All codes are subject to interpretation and revision. It is always advisable to check with the code enforcement authority with jurisdiction about the latest requirements. The information contained herein, while believed to be accurate, is provided for general reference purposes only. Changes occur in Codes regularly. Elevator Concepts is not responsible for any condition arising out of the use of the information provided herein.

Type 1L

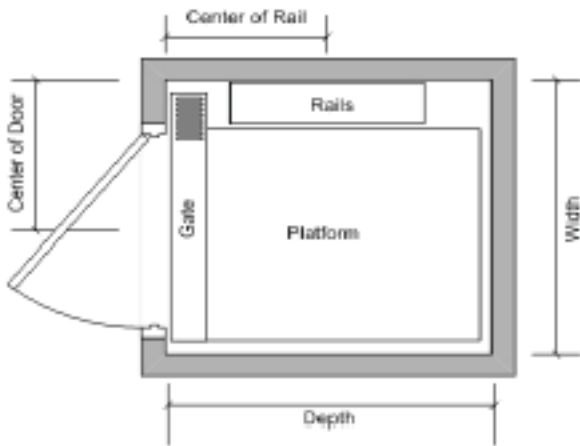

Type 1R

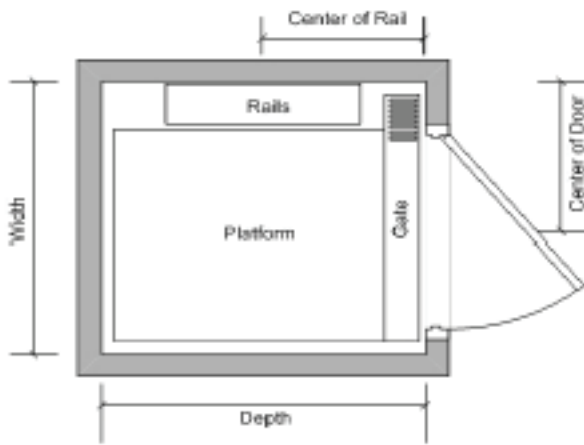

Type 2

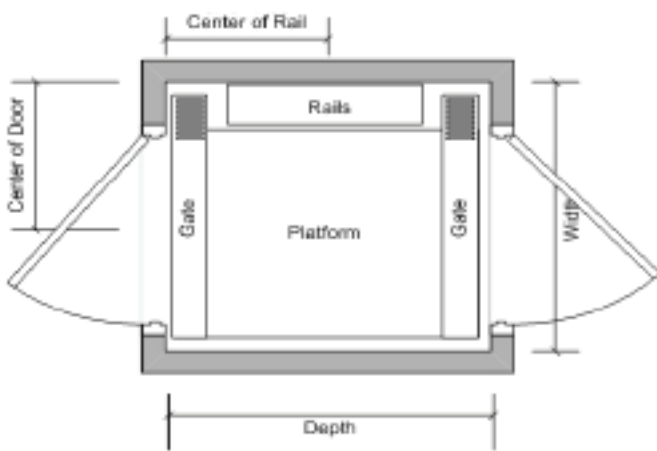

	Capacity	Width	Depth	Minimum Pit	Minimum Overhead								
Accordion Gate													
	36x48	1000	52	57	6	96							
	36x54	1000	52	63	6	96							
	36x60	1000	52	69	6	96							
	40x48	1000	56	57	6	96							
	40x54	1000	56	63	6	96							
	42x60	1400	59	69	8	96							
	48x54	1400	61	63	8	96							
2-Speed Gate													
	42x54	1000	65	73	12	120							
	48x54	1000	67	73	12	120							
	42x60	1400	65	79	12	120							

Type 3

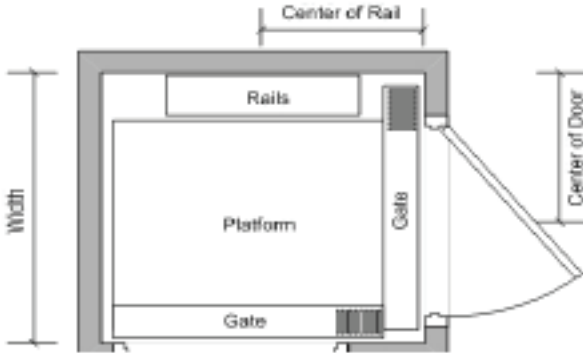

Type 4

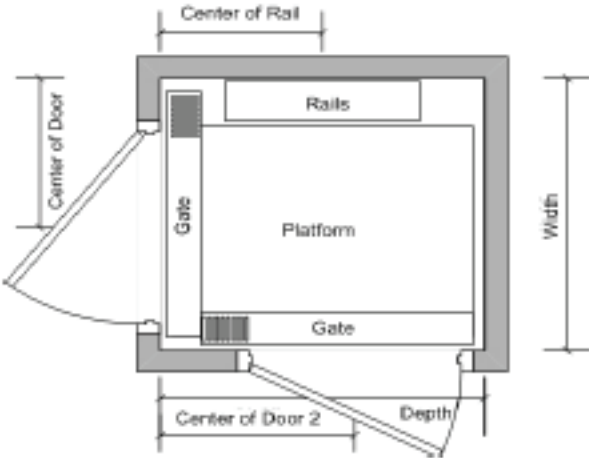

Type 5

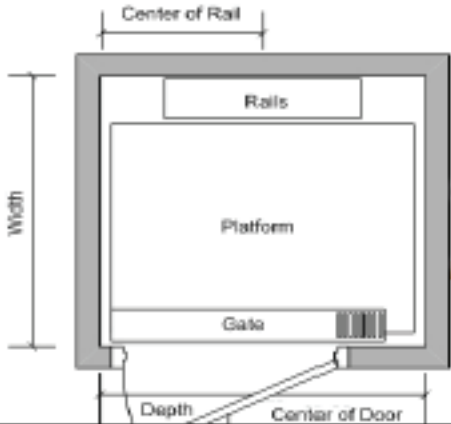

Sample Plan Views
Do Not Use For Construction

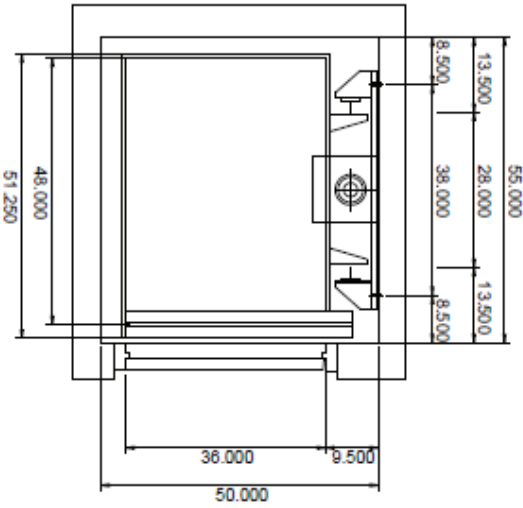

1 Accordion Gate

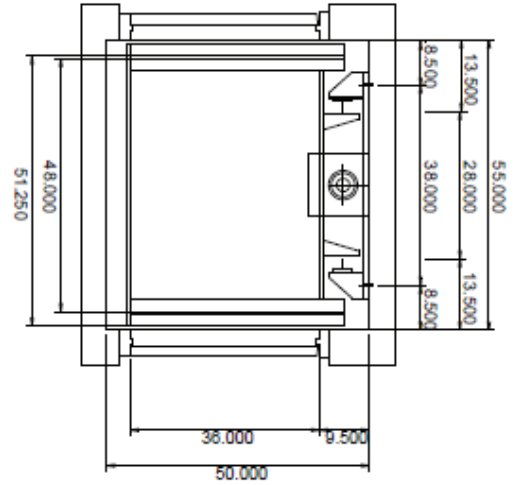

2 Accordion Gates

RESIDENTIAL
36" x 48" CAR SIZE

Wrap Around Gate

LULA
36" x 54" CAR SIZE

Accordion Gate

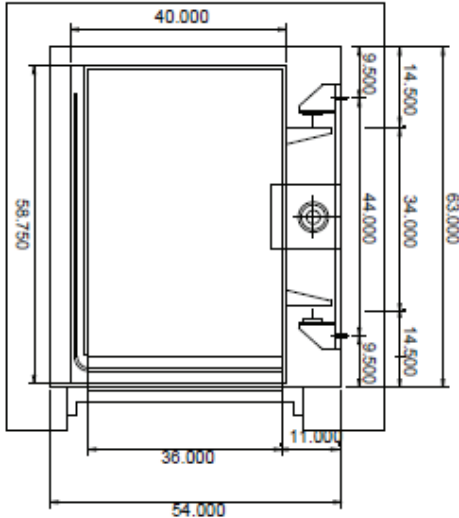

Wrap Around Gate

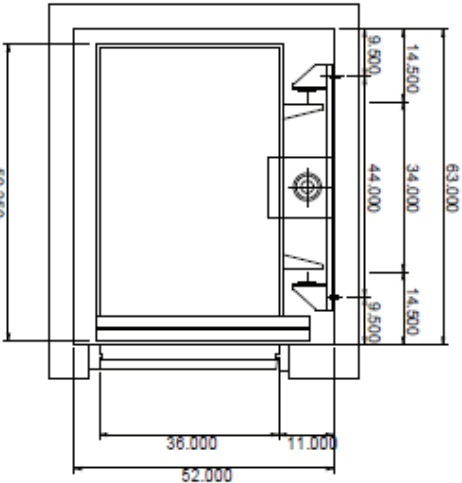

Accordion Gate

LULA
42 x 60 CAR SIZE
MANUAL DOORS

Wrap Around Gate

LULA
42 x 60 CAR SIZE
POWER DOORS

Accordion Gate