

Elevator Specifications

Model & Type	XDRUM
Capacity	500#
Code	ASME A17.1 Section 5 - Residential
Speed	.35 FPM
Travel	.30' maximum
Platform (Car Area)*	.36" x 48"
Hatch	.52" x 57"
Pit	.12"
Overhead	.8'6"
Landings	Up to 6
Car Openings	.1 or 2
Door Size	.36" x 80"
Std. Door Type	.Swing
Operation	.Single button automatic
Power Supply	.208 volt , 1 phase, 30 amp

CAB

Wall Finish	.Laminate
Gate Type	.Accordion
Ceiling Finish	.Laminate
Height	.80"
Handrails	.1
Floor Covering	.By Others

FIXTURES

COP	.1
Hall Station	.1 per landing
Telephone cabinet	.Optional
Emergency Light	.Optional
Finish	.Stainless Steel

CONTROL

Controller Logic	.PLC
Control Voltage	.24 volt
Landing System	.Magnetic
Drive Type	.VVVF
Interlocks	.Included
Gate Operation	.Manual
Door Operation	.Manual

*36" x 54" (hatch 52" x 63") also available as standard size.

These specifications represent our standard residential elevator unit. If any of these specifications must be modified to suit your needs, please contact us to discuss your special requirements.

Elevator Concepts LTD continually improves its products. This specification is subject to change at the sole discretion of Elevator Concepts LTD.

Drawings

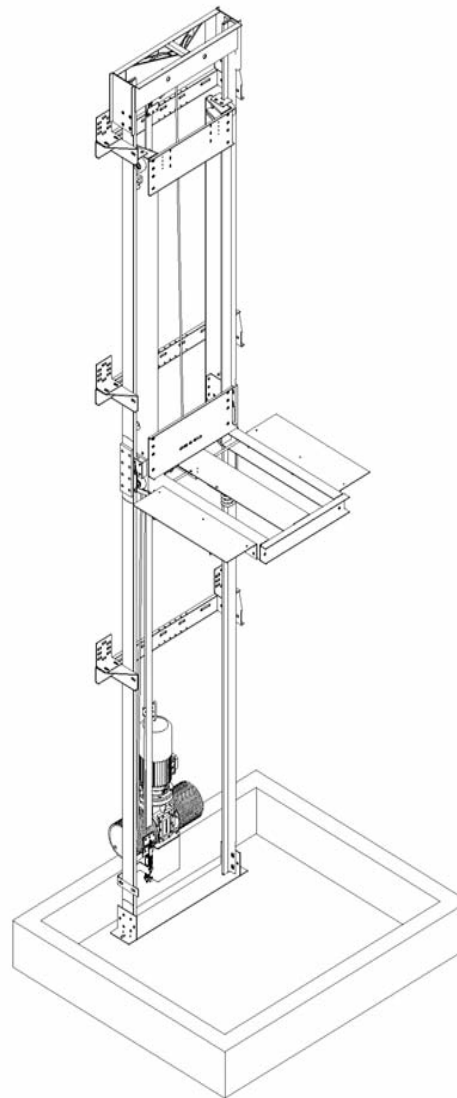

Note: Typical drawing for illustration only. Do not construct hoistway from this drawing. Consult the factory or your dealer.

Installation must be done in accordance with manufacturer's published installation and operation instructions as furnished with equipment, and in compliance with requirements of all applicable codes. Elevator Concepts LTD assumes no liability for equipment improperly installed.

ELEVATOR CONCEPTS LTD

Revised 4/11

Residential Elevators Basement Winding Drum

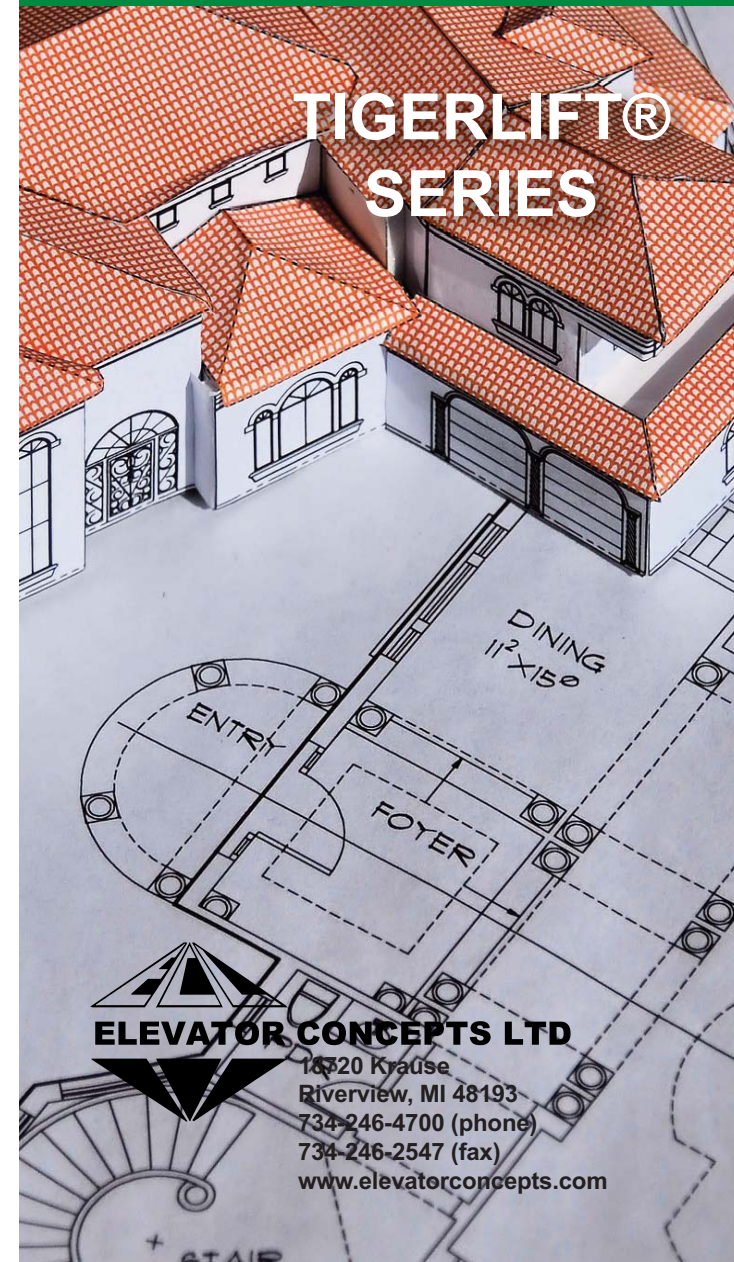

ELEVATOR CONCEPTS LTD

16520 Krause
Riverview, MI 48193
734-246-4700 (phone)
734-246-2547 (fax)
www.elevatorconcepts.com

Residential Elevators

Since 1986 Elevator Concepts LTD has designed and manufactured high quality TIGER LIFT® elevators specifically for the residential and access market. While we have an extensive line of standard products, we specialize in custom designed elevators to suit unique structural or aesthetic requirements.

Raising the Standards

TIGER LIFT® elevators are engineered and manufactured to deliver a smooth, quiet ride while incorporating the highest standards and safety features not found in other residential elevators. Our compact designs require the space of an average home closet resulting in minimal disruption to the floor plan and traffic flow.

To ensure flexible design and installation options, we have developed elevators based on 5 drive platforms:

- overhead
- basement traction
- direct hydraulic
- roped hydraulic
- winding drum

No other manufacturer offers a product line this extensive.



Visit us on the web @ www.elevatorconcepts.com

Cab Packages

Selecting the finished look of your elevator is one of the most important decisions you will make when choosing a TIGER LIFT® elevator. To assist in your decision, our designers have created standard cab packages featuring stylish, finished looks that easily fit any decorating need. We offer everything from durable and decorative laminate walls... to hand-crafted recessed or raised hardwood panels.

Each cab package includes such standard amenities as: finished laminate ceiling, recessed incandescent light fixtures, brushed aluminum handrails, stainless car panel and hall buttons, unfinished floor and manual accordion gates.

Customizing

Our team of designers and engineers can custom manufacture an elevator to match virtually any décor, structural condition or budget restraints, making the TIGER LIFT® a perfect choice for both existing buildings and new home construction.

Cabs fabricated of multiple finishes, partial or full glass, mirror or stainless steel are popular customized cab interior options. Manual or power wrap-around gates or Bostwick scissor gates are alternative gate styles available at an additional charge.

Contact a Sales Representative today at (734) 246-4700 for available design options, custom orders and current pricing or visit us on the web at www.elevatorconcepts.com.

Standard Features- Winding Drum

- Shop drawings
- 2 stop / 1 gate (short side) / 12' travel
- 500# capacity - 36 x 48" platform
- 80" cab with recessed lights & handrail
- 6# T rails & brackets
- VVVF Drive for smooth starts & stops
- High Efficiency gearbox
- PLC controls with auto car lights
- Rupture valve & pressure switch
- Electric door locks
- Stainless car panel and hall buttons
- Magnetic landing system
- Steel sling with slide guide & platform
- Buffers and pit equipment
- All wiring material and conduit

Optional Features

- Phone box and phone
- Hands free phone
- Emergency light
- Key switches
- Brass fixtures
- Up to 36 x 60 platform with 950# capacity
- Custom Cab finish
- Power gate operator

Warranty

Your investment with Elevator Concepts is protected with a one year limited warranty against defects in material or workmanship.

